

Medidas em milímetros (mm)

DESCRIÇÃO CATÁLOGO:  
ACABAMENTO PARA REGISTROS PADRÃO DECA/DOCOL E SIMILARES

Referência	Material	Acabamento	Modelo	Modelo
091102	Plásticos de engenharia	Cromado	Similar Itapema	Deca/Docol
091104	Plásticos de engenharia	Branco	Similar Itapema	Deca/Docol

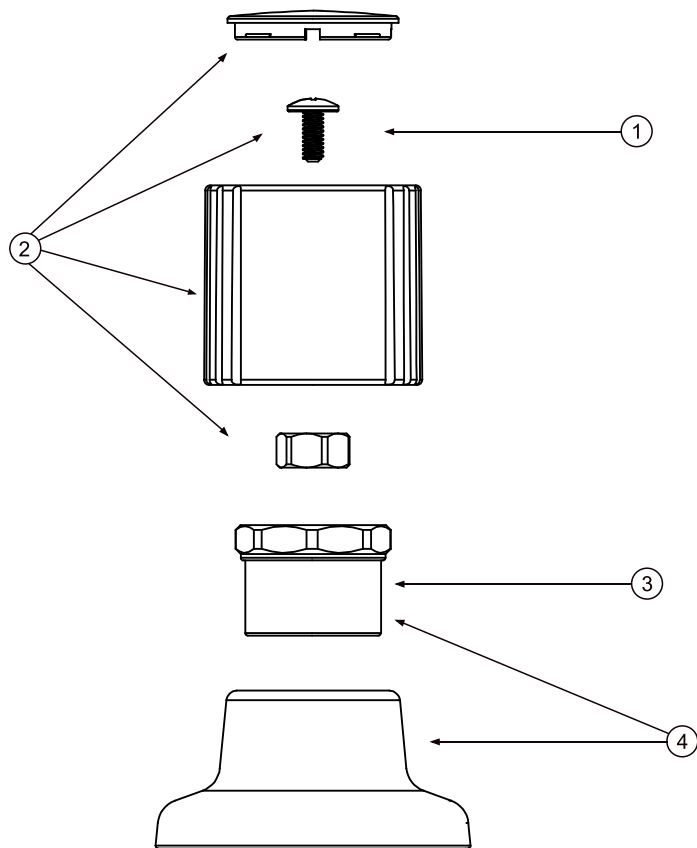



**091102-21 / ITENS**

1	100502-450	PARAFUSO AÇO INOX - 5/32"
2	071102-21	VOLANTE DE ABS CROMADO DOCOL C-40
3	100111-41	PREME CANOPLA ITAPEMA
4	081101-41	CANOPLA ABS MODELO ITAPEMA

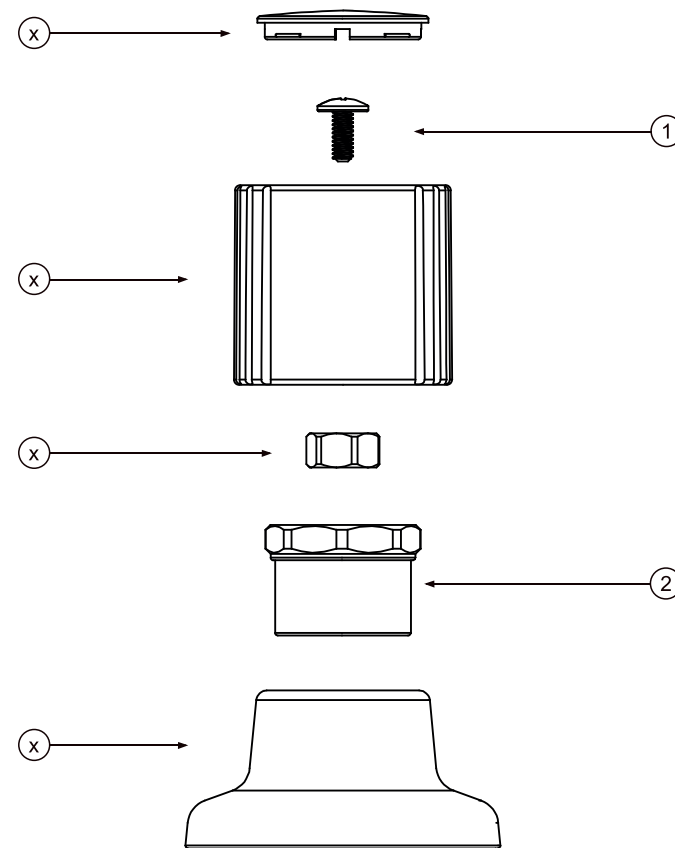

**091104-21 / ITENS**

1	100502-450	PARAFUSO AÇO INOX - 5/32"
2	100111-41	PREME CANOPLA ITAPEMA
x	-	NÃO COMERCIALIZADO INDIVIDUALMENTE

VISTA EXPLODIDA.





Imagem meramente ilustrativa.

VISTA DAS ETAPAS DE INSTALAÇÃO DO PRODUTO.



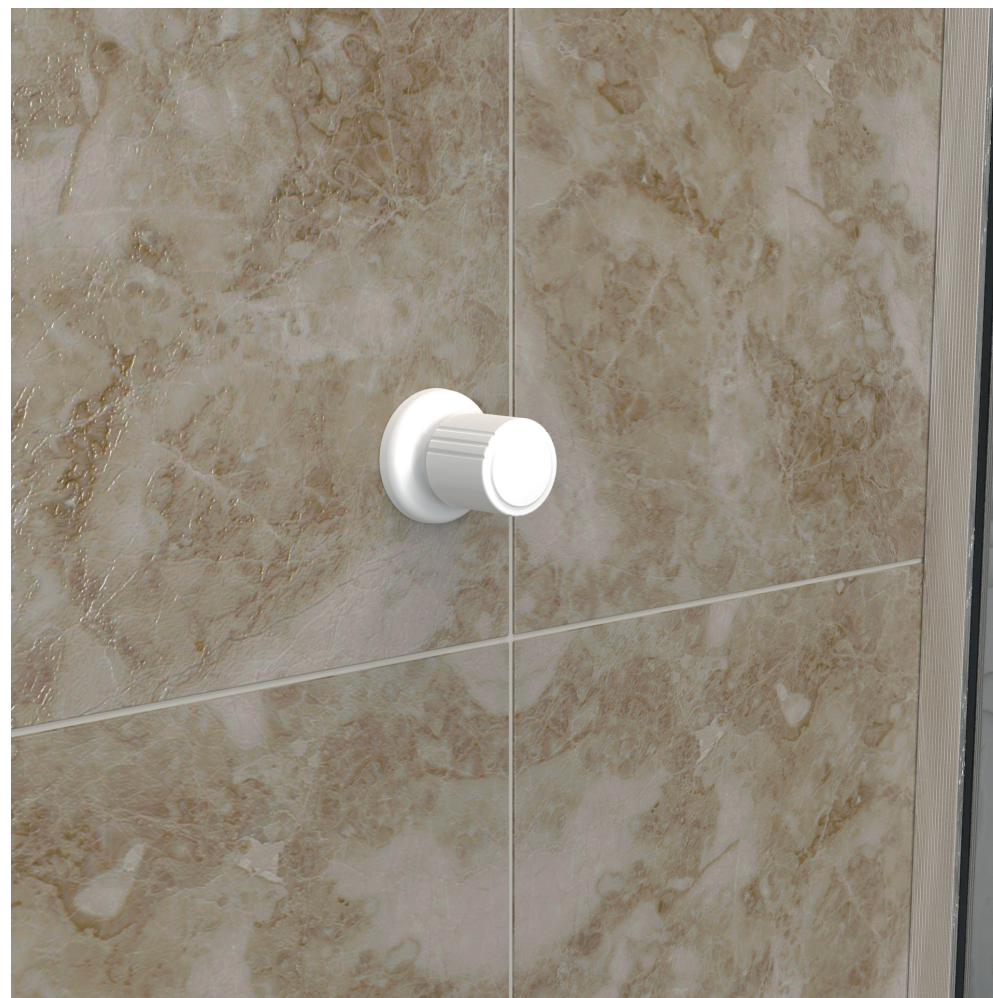

VISTA DE APLICAÇÃO.





Rua João Pessoa, 2566 | Blumenau - SC  
CEP 89036-003 - Fone: +55 47 3331.0800  
CNPJ: 81.604.803/0001-57



[www.blukit.com.br](http://www.blukit.com.br)



[facebook.com.br/canalblukit](https://facebook.com.br/canalblukit)



[youtube.com.br/canalblukit](https://youtube.com.br/canalblukit)